



**CM8SW**  
**SUBWOOFER**



# Congratulations!

Thank you for choosing a Niles ceiling mount loudspeaker. With proper installation and operation, you'll enjoy years of trouble-free use.

The CM8SW is a ceiling mount subwoofer uniquely designed to provide unobtrusive low frequency augmentation. The selectable high and low-pass filters make it suitable for use with a wide variety of satellite speakers.

Niles manufactures the industry's most complete line of custom installation components and accessories for audio/video systems. For a free full line catalog write: Niles, Catalog Request, P.O. Box 160818, Miami, Florida 33116-0818

## TABLE OF CONTENTS

FEATURES AND BENEFITS	2
HOW MANY SUBWOOFERS?	4
CONNECTIONS	5
IMPEDANCE	7
TREATMENT & PLACEMENT	9
INSTALLATION FUNDAMENTALS	10
INSTALLATION IN NEW CONSTRUCTION	14
INSTALLATION IN EXISTING CONSTRUCTION	15
FINAL INSTALLATION IN NEW OR EXISTING CONSTRUCTION	16
OPERATION	18
SPECIFICATIONS	19
WARRANTY REGISTRATION CARD	21
LIMITED WARRANTY	22

---

# Features and Benefits

## TCC Speaker Cone

The Niles CM8SW is a high-performance passive subwoofer that compliments the entire Niles ceiling mount loudspeaker line. It's dual voice-coil injection molded TCC (talc, carbon and ceramic) woofer provides outstanding bass response

## High-Power Handling

The CM8SW employs an exceptionally heavy-duty magnet/voice-coil/spider assembly that is capable of handling high power amplifiers (up to 150 watts).

*The illustration below shows how a typical Niles CM loudspeaker mounts into a ceiling.*

New Construction Bracket serves as a "hole saver" when drywall has not been applied. It is not necessary when retrofitting to existing ceilings.

**Figure 1**  
Model CM8SW Shown

Knockout wire tie allows the wire to be secured to the bracket throughout the new construction process. It knocks out cleanly when the speaker is installed.

New construction wings instantly snap into the bracket without screws.

Wings are scored for easy size trimming.

Brackets and wings attach to the ceiling joists with nails or screws.

Dogs swivel 90°, then clamp the speaker frame to the drywall.

Frames are molded with a slight texture to assure good paint adhesion.

Mounting screws tighten the "Dogs", clamping the speaker to the drywall

Rust-proof aluminum Grilles make the CM8SW series perfect for moist environments.

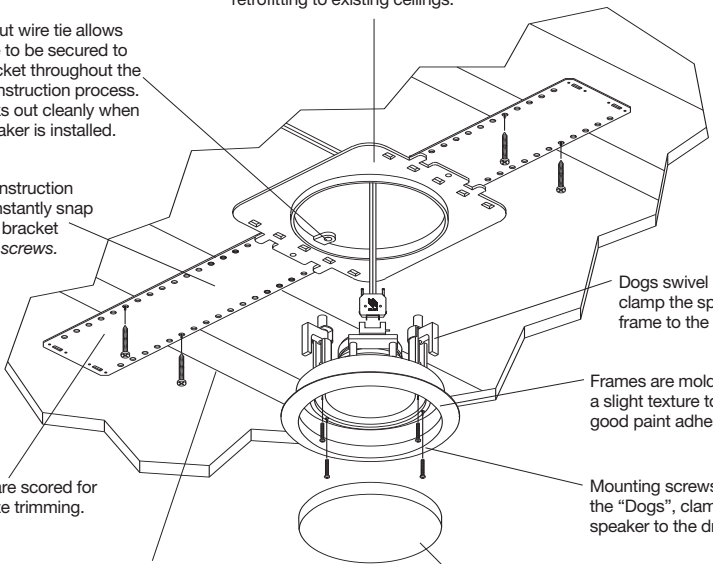

**Figure 2**



The CM8SW ceiling mount subwoofer includes an easy access, baffle mounted high pass filter to prevent over-excursion of the satellite's woofers.

**Figure 3**



The CM8SW ceiling mount subwoofer includes an easy access, baffle mounted low pass frequency selection switch.

### **Infinite Baffle Design**

The CM8SW is designed for optimum low frequency reproduction in traditional ceiling environments and varying air volumes. It does not require a special enclosure to provide high performance.

### **Selectable High-Pass Filter**

Installers can also select whether or not to filter the low frequencies from the satellite speakers at a fixed frequency of 120Hz. Like the low-pass filter, this selection is accessed via baffle mounted controls (See Figure 2).

### **Adjustable Low Pass Filter**

Installers can select passive crossover for both woofer and satellite speakers via baffle-mounted controls that are accessible even after the subwoofer has been installed (See Figure 3).

### **Weather-Resistant Construction**

All components of the CM8SW are weather resistant. The aluminum grille and stainless steel mounting screws are rustproof. This makes the subwoofer ideal for moist environments which would cause some brands of speakers to discolor. Protected outdoor installations are perfectly suited for the CM8SW.

### **MicroPerf™ Grilles**

The CM8SW employs Niles' exclusive MicroPerf grille construction. The exceptionally tight hole pattern provides acoustic transparency at all audio frequencies and enables the woofer element to remain invisible. MicroPerf grilles can be painted to blend seamlessly with the surrounding decor.

### **No-Strip Speaker Wire Terminals**

Dual Niles patented gold-plated no-strip speaker wire terminal connectors accommodates 12-18 gauge wire.

### **Easy Installation**

The CM8SW employs a bracketless mounting system for existing ceilings. Simply cut a hole in the mounting surface, remove the grille from the subwoofer, connect the wires and place the speaker in the hole. Then tighten the four mounting "dogs" via the front panel screws. The dogs first swivel 90°, then clamp the frame to the drywall as the screws are tightened.

### **Hole Saving Bracket**

Available as an optional accessory, the CM8 New Construction Bracket can be installed as a "hole-saver" before the drywall goes up. The drywall contractor cuts the hole as the drywall is installed, reducing installation time and minimizing the chances for lost wires.

# How Many Subwoofers?

For most applications a single CM8SW is appropriate. However, in large rooms, high performance listening rooms or in home theaters, an array of two or more CM8SW will deliver astounding results. Unlike other subwoofer systems, a Niles Subwoofer Array is concealed. Consider the distance between the subwoofer(s) and the listener, the size of the amplifier and the desired quality and volume of sound when deciding how many CM8SWs to install in your home.

## Decibels and Power

<b>65dB</b>	<b>Conversation</b> at three feet.
<b>75dB</b>	<b>Sewing Machine</b> at three feet.
<b>85dB</b>	<b>Vacuum Cleaner</b> at 10 feet.
<b>95dB</b>	<b>Subway Train</b> entering a station at 20 feet.
<b>3dB</b>	The smallest difference of sound the human ear can easily detect.
<b>10dB</b>	Perceived as twice as much loudness if it is an increase (half as much if it is a decrease).

*Any speaker requires twice as much amplifier power to increase 3dB and ten times as much power to increase 10dB.*

## Comparison of 1, 2 or 4 Subwoofers 16' x 18' x 8' Room @ 12'

	25 Watts	100 Watts
<b>1 Sub</b>	<b>95dB</b>	<b>101dB</b>
<b>2 Subs</b>	<b>100dB</b>	<b>106dB</b>
<b>VLSA of 4 Subs</b>	<b>103dB</b>	<b>109dB</b>

2 x Watts = 3dB Increase in Volume.  
 2 x Subs = 3dB Increase in Volume.  
 2 x Subs = 1/2 the subwoofer excursion for the same volume.

*If you double the distance from the subwoofer to the primary listening position you decrease the volume by 4 to 6dB.*

## Single Stereo Subwoofer

One CM8SW can produce the bass sound from both the left and the right channels because of its unique dual voice coil design. One voice coil powers the left channel and the other powers the right channel. A stereo crossover divides the signal and filters it according to the position of the switches on the front panel. A single stereo subwoofer is compatible with any 4 ohm stable amplifier. Eight ohm stable amplifiers may be used with a Niles IM volume control (see Impedance section on Page 7)

## Dual Subwoofer Systems

Using two CM8SW subwoofers in a system raises the maximum attainable volume of the system by 3dB. Additionally, at lower volumes, excursion — and therefore distortion levels — are reduced. In a large room, or a home theater system, the effect on bass quality is extremely desirable. Another 2dB increase is possible if the voice coils of each are CM8SW paralleled. This requires a multi-channel amplifier or an amplifier capable of driving the 2 to 2.6 ohm load of the overall system.

## VLSA Installations

A Very Large Subwoofer Array (VLSA) installation lowers the amount of excursion required to achieve a high sound pressure level. Lowering excursion dramatically improves the quality of the sound. VLSA installations are most appropriate when the listener appreciates detail and bass extension, but must have a concealed installation. A VLSA of four subwoofers must have a multichannel amplifier with one channel assigned to each subwoofer.

# Connections

## Single Stereo Subwoofer

A four conductor (Left+, Left-, Right+ and Right-) wire 16 gauge or larger (see sidebar on speaker wire gauge) is run from the amplifier location to the local volume control (See Figure 4).

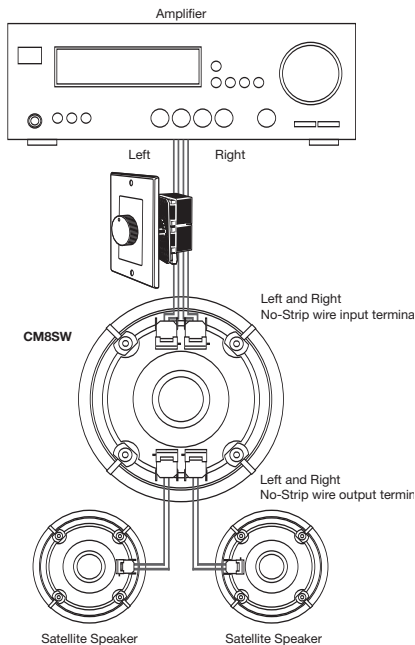

**Figure 4**

A Single CM8SW Hook-Up

From the local volume control the four conductor cable is run to the CM8SW and connected to the Input connectors. A two conductor wire is connected to each of the stereo outputs and fed to the left and right speakers. Now, the volume control will raise and lower the volume for the subwoofer and the left and right speakers simultaneously. Additionally, the crossover is now connected so that the crossover switches can be adjusted.

## Dual Subwoofer Systems

A four conductor (Left+, Left-, Right+ and Right-) wire 16 gauge or larger (see sidebar on speaker wire gauge) is run from the amplifier location to the local volume control (See Figure 5).

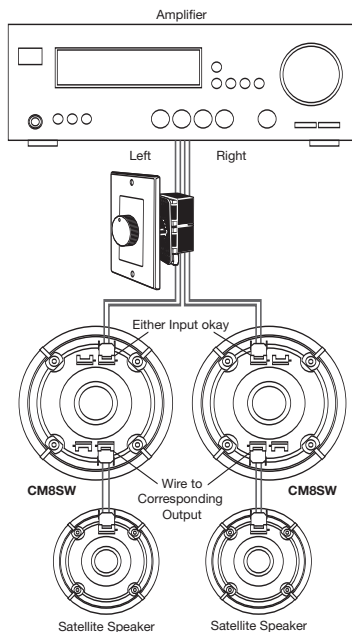

**Figure 5**

A Dual CM8SW Hook-Up

From the local volume control a two conductor cable is run to each of the CM8SWs and connected to either the left or the right Input connectors.

Each of the satellite speakers must be connected to the correct subwoofer. Typically, a two conductor wire is connected to one of the outputs on the left channel subwoofer and fed to the left satellite speaker and another two conductor wire connects the right channel subwoofer and satellite.

Now, the volume control will raise and lower the volume for the subwoofer and

the left and right speakers simultaneously. Additionally, the crossovers are now connected so that the crossover switches can be adjusted to your requirements. You must adjust the crossovers on each speaker with this hook-up.

Optionally, a jumper of wire may be connected between the L+ and the R+; and between the L- and the R-. This connects both voice coils of the CM8SW, giving you a 2dB increase in output. Since each subwoofer's impedance drops from 8Ω to 4Ω, make sure your amplifier is 2Ω stable to accommodate the satellite speaker's impedance. (See Figure 6).

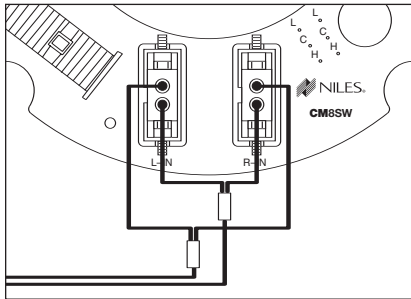

**Figure 6**  
Connecting the two voice coils in parallel with a jumper (a piece of speaker wire).

### Very Large Subwoofer Array (VLSA)

Using four or more CM8SW subwoofers in a system creates a system of unprecedented clarity, with stunning bass impact and potentially extraordinary maximum volume capability. Because of the extremely low impedance of a parallel VLSA system, multiple channel amplifiers are normally used to power them. Because of this, in-wall volume controls are incompatible with VLSA systems.

In a system of this type, it is recommended that the satellite speakers be driven full range (or with an external electronic

crossover) by a separate amplifier channel. Connections are straight-forward; two conductor wires connect each amplifier channel to each individual subwoofer. (See Figure 7).

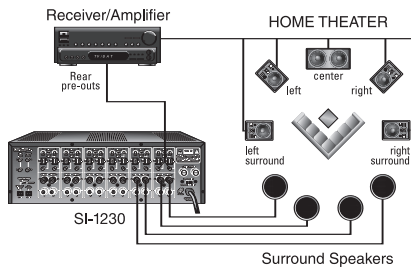

**Figure 7**  
Connections to a VLSA are normally made from each CM8SW to a multi-channel amplifier like the Niles SI-1230 twelve channel amplifier.

Each CM8SW has a jumper installed to parallel the voice coils for maximum efficiency. (See Figure 6).

The crossover controls on each subwoofer affect only the subwoofer response. Level controls on the amplifiers facilitate blending and compensation for placement.

### Speaker Wire

For most applications, we recommend you use 16 or 18 gauge wire. For wiring runs longer than 80 feet we recommend 14 gauge wire. The No-Strip speaker wire terminals can accommodate 12-20 gauge wire. When you run wire inside walls, special jacketing (CL-2 or CL-3) is required to both protect the wire and for fire prevention. In some areas conduit is required. For a trouble-free installation, low voltage wire such as speaker wire must be run in accordance with the National Electrical Code and any applicable provisions of the local building code. Consult your local Niles dealer or your building contractor if you are unsure of code requirements in your area.

# Impedance

## With One or Two Subwoofers

When one or two CM8SW subwoofers are connected to the satellite speakers, the overall system impedance to the amplifier lowers.

System Impedance in Ohms ( $\Omega$ ) One or Two Subwoofers		
	8 $\Omega$ Sats	4 $\Omega$ Sats
1 Sub	4 $\Omega$	2.6 $\Omega$
2 Subs @8 $\Omega$ each	4 $\Omega$	2.6 $\Omega$
2 Subs @4 $\Omega$ each	2.6 $\Omega$	2 $\Omega$

If the impedance is too low for your amplifier utilize a Niles speaker selector or IM volume control to match the impedance.

## VLSA (Four or More Subwoofers)

A VLSA (Very Large Subwoofer Array) installation lowers the amount of excursion required to achieve a high sound pressure level. Lowering excursion dramatically improves the quality of the sound. VLSA installations are most appropriate when the listener appreciates detail and bass extension, but must have a concealed installation.

Each subwoofer should have its voice coils connected in parallel for full output, therefore **the impedance of each is four ohms**. Because of this low impedance, a multi-channel amplifier stable to 4 ohms is the best way to drive more than two subwoofers. Each CM8SW is connected to its own channel of a multi-channel amplifier.

## Check Your Amplifier's Specs

Every amplifier has a minimum impedance specifications. Check your owner's manual to determine whether or not your amplifier is capable of driving a four ohm load. This

specification may also be noted on the rear panel of the amplifier. If your amplifier is not able to drive a four ohm load it may only be used to power a CM8SW satellite/subwoofer system when an impedance magnifying volume control is incorporated into the system

An amplifier stable to four ohms may be connected without impedance matching devices. Parallel connections via the "A" speaker terminals to one or two CM8SW subwoofers (If the voice coils are not in parallel) and one pair of eight ohm satellite speakers results in a four ohm load.

*The "B" speaker terminals cannot be used to power a second pair of speakers anymore.* The low impedance drive capability of your amplifier is already utilized by the satellite/subwoofer combination. If you are connecting other speakers in other rooms you must install either a speaker selector or impedance magnifying volume controls.

A few professional/audiophile amplifiers advertise the capability of driving two ohm speaker loads. These amplifiers may be used without impedance matching devices if the rating is quoted as "RMS" or "Continuous" power and the amp does not push too much power.



## Using Speaker Selectors With Standard Volume Controls

In multi-room systems with standard volume controls any Niles speaker selector will maintain a four ohm load if you leave one set of room outputs unused for every speaker system with an impedance of less than four ohms (such as a CM8SW connected to a pair of four ohm satellite speakers). The protection switch must be constantly engaged. Niles HDL series speaker selectors have a rear panel constant protection feature. (See Figure 8).

**The benefit of a speaker selector is that even with the protection circuit constantly engaged, more power will be delivered to any single pair of speakers playing by itself (all other speakers off).**

In a multi-room system there is one indispensable control for true convenience—a local volume control. It allows you to adjust the volume of the speakers and the subwoofer without leaving the room.

Niles makes a wide range of high performance indoor and outdoor volume controls in Standard or Decora® style face plates (just like your light switches and dimmers). All of these volume controls enable full power to be delivered to each speaker system when turned all the way up.

**The combination of a speaker selector and a standard volume control will deliver high volume when only one pair of speakers is playing.**

## Using Impedance Magnifying Volume Controls

The simplest way to increase the impedance of a satellite/subwoofer system is to install a Niles VCS-2D-IM or VCS-2S-IM impedance magnifying volume control instead of a standard volume control. This control has a behind the wall jumper which is set at the time of installation to “magnify” the speaker system impedance. (See Figure 9).

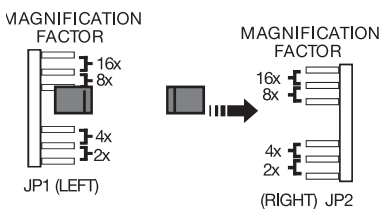

For example: In the two times position, an IM volume control will enable an eight ohm stable amplifier to play a 4 ohm speaker system without overheating. The available power will decrease, which you will perceive as a 3dB drop in maximum undistorted volume.

**If the jumper is set to the 4x position, a 6dB drop in volume will be perceived.**

**If the jumper is set to the 8x position, a 9dB drop in volume will be perceived.**

A 10dB drop is perceived as half as loud, so there are limits to the amount of magnification you can use unless the amplifier is very powerful (3dB increase every time you double the power) or you never listen at high volumes. Consult the Decibels and Power chart on page 4.

# Treatment & Placement

Typically, sheetrock encloses the subwoofer in most installations. Sheetrock has a fairly loud resonant “twang” compared to the rigid non-resonant enclosures of most floor standing subwoofers. None of the following modifications are absolutely necessary, however any one or combination of them will improve the performance of the subwoofer.

## Minimum Enclosure Size

The CM8SW will produce magnificent results if the ceiling air cavity above the woofer is a minimum of 1900 cubic inches. If the ceiling joists center measure 5-1/2” deep (2x6) and are spaced 14-1/4” apart (16” spacing) you would want the length of the air cavity to be a minimum of 24-1/4”. A larger cavity is fine.

## Insulation

Lay a batten of fiberglass insulation (e.g. R-19 un-batted insulation) on top of the speaker. If you have more than one subwoofer in the room, place the same amount of insulation above each subwoofer. If your enclosure is smaller than the recommended 1900 cubic inches, try packing more insulation into the space above the speaker. This effectively increases the enclosure size.

## Enclosure Bracing

Insert small pieces of 1x2 or 1x1 scrap wood as wedges between the ceiling sheetrock and the floor above if possible. Do not use too long of a piece as you could create a bulge in the ceiling surface.

## Enclosure Lining

Purchase some subwoofer damping material from a car stereo store (there are vari-

ous brands available, e.g. Dynamat™). Apply the damping material to the bottom of the floor above the CM8SW and to the top of the surrounding sheetrock ceiling beside the subwoofer.

## Speaker Placement Techniques

Although the CM8SW has extensive ability to compensate for unusual placements with its crossover switches; placement is still the primary tool for satisfying your particular listening needs.

### Maximizing Output

**Corner Placement** – Placing your subwoofer near a corner will increase the volume of bass sound produced by the subwoofer! This is called the boundary effect. Generally, you can expect a 3dB increase in sound pressure level with corner placement.

**Proximity** – Place the subwoofer as close as possible to the primary listening position. Sound dissipates indoors at approximately 4dB to 6dB each time you double the distance from the subwoofer to the listener. Therefore you can expect a 4dB to 6dB increase in output every time you halve the distance from the subwoofer to the listener.

### Improving the Stereo Image

#### **Near Satellite**

Place the subwoofer(s) as close as possible to the satellite speakers.

# Installation Fundamentals

## Introduction

If you have doubts about whether you are capable of installing a ceiling mount speaker, consult a Niles dealer or professional installer. They have special tools, techniques, and experience to make the impossible possible. The installer can provide you with an estimate before any work is done.

## Running the Speaker Wire in New Construction

Plan to schedule the speaker wiring after the electrical wiring is finished. That way you can avoid wire routes which could potentially induce hum over the speaker wire. The basic rules are:

- Never run speaker wire through the same hole as an electrical cable.
- Never run speaker wire into the same J-box as electrical cable.
- Avoid running the speaker wire beside the electrical cable. Keep it at least three or four feet away from any electrical power cable.

Side-by-side wiring is unavoidable in particular spots in every house, just move the

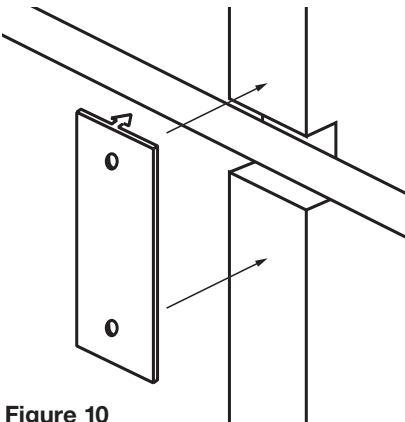

Figure 10

speaker wire route away as soon as possible. If construction forces a side by side run for more than ten feet, install metal conduit or shielded speaker wire. Low-voltage wires such as doorbells, intercoms, telephone, security, or television cannot cause interference or hum on your speaker wires, so you can safely run all of them at the same time, through the same holes, side-by-side.

Before you drill any holes, mount open backed J-boxes where the volume controls and stereo equipment will be. If you are using the optional hole saving brackets (CM8 Series New Construction Bracket kit-FG00656) attach the wings and install them (See figure 15 and 16).

### Safety First!

Wear gloves, safety goggles and head protection when drilling. Avoid nails, they ruin bits and they can create injury.

### Drilling

Use a bit that is large enough for the wires you plan to run. An auger bit is the preferred bit for rough-in wiring. It will actually pull itself through the wood, so that the drill motor, not you, does most of the work. You will be drilling a lot of holes, so this is important.

Always drill the holes in the center of the stud. If you have to notch the stud or drill the hole closer than one inch from the edge of the stud, protect the wire with a nail plate (See Figure 10).

When drilling holes in ceiling joists drill in the center of the joists and try to locate the hole near the end of the joist. DO NOT drill through a “gluelam” or any load bearing beam without the direction of your contractor.

Try to line the holes up perfectly, because it makes pulling the wire much easier. A good technique is to snap a chalk line across the face of the studs or against the

bottom of the ceiling joists. Then work backward so that you can always see the holes you have already drilled. Paying careful attention to this will save you a lot of time later on!

### Pulling the Cable

Pull the cable in sections (from the stereo to the volume control, from the volume control to the speaker). Start with the longest sections and use left over wire to complete the short sections. If you plan to pull many rooms at the same time through a central route, walk off the distance to each destination, add a generous fudge factor for turns and other obstacles, then cut off each section so that you have a bundle of wires you can pull at once.

Whenever you run the wire further than four and one half feet from a hole in a stud or joist (open attic space, going up walls, etc.), fasten the wire to the joists or studs using cable clamps or appropriately sized wire staples. The wire should not have large sags in it, nor should it be too tight. Try to protect the wire from being stepped on in attics or other unfinished crawl spaces. There are guard strips, raceways and conduits which can be used to protect the cable. Consult the local building code for special requirements in your area.

### **Concealing Speaker Wire in Existing Walls**

This is actually a fairly simple task if you restrict your choice of speaker locations and wire routes to the ceilings or interior walls of your home. Interior walls in almost all North American residences are hollow, so it is easy to flush mount speakers into them and route new speaker cable around the house. What you see when you look at the painted wall board, plaster, or paneling is only the skin of the wall. Behind the skin is the skeleton; two-by-four wood or metal “studs” running vertically from the floor to

the ceiling in walls and two-by-six or larger “joists” running horizontally in the ceilings and floors. In between the studs and the joists is the space for the wiring and plumbing of your home.

Exterior walls are different. They must insulate the house from the heat and cold outside, so they are stuffed with insulation. The national building code requires that the hollow wall space in exterior walls be broken by a horizontal stud placed between the vertical studs. This “fire blocking” makes it very difficult to retrofit long lengths of wire. In some areas of the country the exterior walls are constructed of solid masonry, and have no hollow space for speaker wires.

Start by examining all the possible routes you might take to run the speaker wire from the speaker to the volume control and back to the stereo. Use a stud sensor or other device to locate the internal structure of the ceiling/wall. You want to avoid as many studs or joists as possible. A typical speaker wire route would be: from the speaker location in the ceiling, across the attic, then down through a top plate (the horizontal 2x4 or 2x6 laid across the vertical studs) to the volume control location, back up to the attic, across the attic, and finally down another wall plate to a j-box in the wall behind the stereo system itself **(See Figure 11)**.

Identify where all of your electrical, phone, and TV wiring is likely to be and plan to route around it all. You can accidentally induce 60Hz hum on your speakers if you run your speaker wire right beside electrical wire for more than a few feet. Try to run speaker wire parallel to power cables at least 3 feet away. To find exactly where an electrical cable is routed, try inspecting the inside of the wall by turning off the breaker for a particular power outlet or switch, removing the cover plate and

switch or receptacle, and shining a penlight into the wall. If you have access to an attic or basement space you can quickly see which part of the wall space is free of obstructions (See Figure 12).

When you don't have access above or below the wall, try to estimate the existing wire and pipe locations from the positions of electrical outlets and plumbed fixtures on both sides of the wall. Take a look at the outside of your house too, sometimes conduit, vents or drain pipe will be visible giving useful information. Choose the route with the fewest potential obstacles.

If your house is built on a slab or you are wiring between two finished floors, look for baseboards which could be removed and replaced with the wire behind them. Doorjamb can be removed and often have enough space for speaker wire all the way around the door (See Figure 13).

Sometimes, an under-the-carpet run is pos-

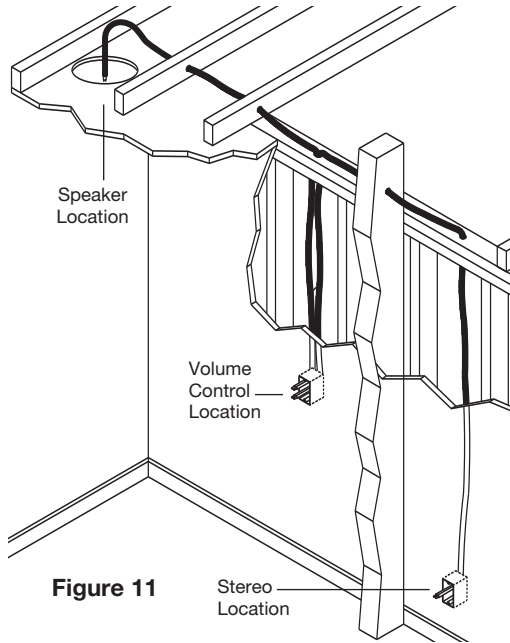

Figure 11

sible (there are special flat speaker wires made for under-the-rug wire runs). As a last resort, heating and air conditioning vents can be used as wire raceways for plenum rated wire (check your local building codes, some municipalities require conduit).

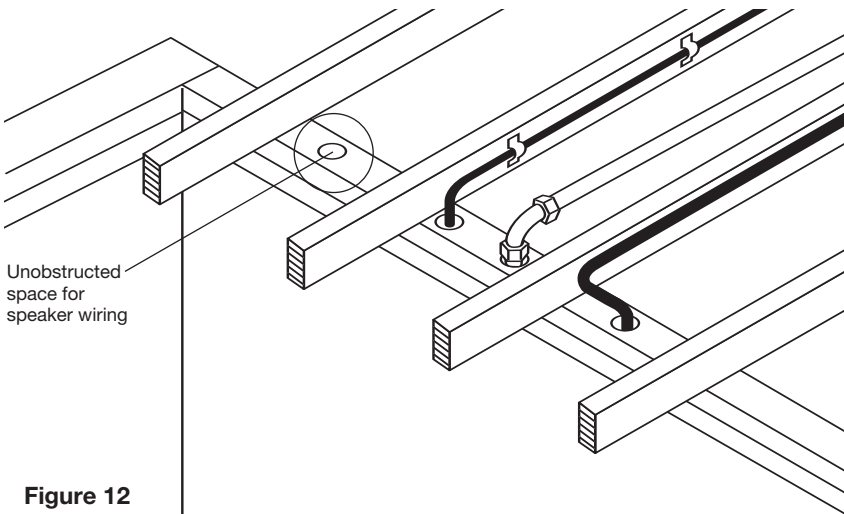
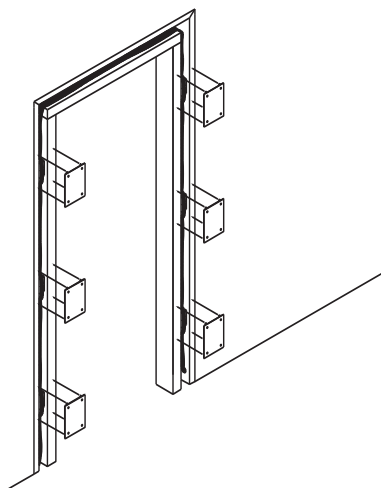

Figure 12

In traditional wood joist/drywall construction you should first cut the hole for the speaker and utilize the large hole to auger holes across the ceiling (through the ceiling joists) for as far as your drill bit will take you. Sometimes, you will need to use the “notching” technique to reach areas your drill bit won’t reach or to turn corners (e.g. to go down the wall when there is not an accessible attic). Don’t make an irregular hole in the drywall. If you carefully cut a rectangular hatch in the drywall you will make your patch at the same time you cut your hole. Notch the bottom of the joists and run the wire through the notches. Protect the wire with nail plates. Once you’ve run your wire replace the hatch you cut using standard drywall “joint tape” and “joint compound” to hold the patch in place, let dry, sand the surface and touch-up the wall with paint (See Figure 14).

Figure 13



The doorjamb has been removed and the speaker wire concealed between the wall and the jamb. Nail plates are installed to protect the wire and the door jamb is replaced.

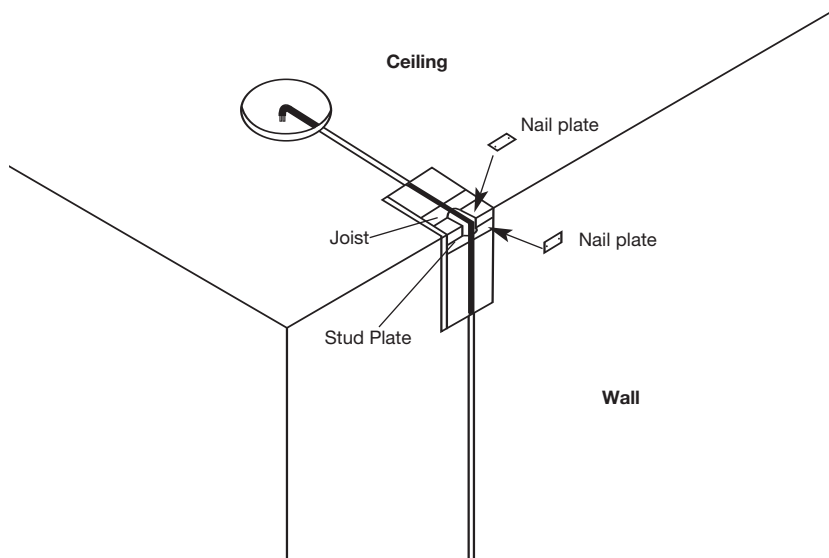

Figure 14 Diagram of ceiling speaker cut-out with ceiling joists notched for wire run.

# Installation in New Construction

## Stage One: Before Drywall is Hung Insulating the Wall Cavity.

If feasible, fill the wall cavity with insulation at this point.

## Mounting The CM8 Series New Construction Bracket

The hole saving bracket enables a faster and cleaner final installation of the speaker. It forces the drywall installer to cut out the speaker hole for you and provides wire ties for the speaker wire, reducing the risks of accidental loss or movement of the wire. In addition, it enables you to align your speakers with other ceiling fixtures with great accuracy since you can really see exactly where the speaker will be.

To install the bracket, first attach the QuickSnap™ new construction wings to the bracket by snapping them into the sides of the bracket. The wings can be shortened by

breaking them along the scored lines if their length will interfere with a corner or eaves. The wings and brackets have centering lines to simplify the placement of the speaker.

Screw one side of the assembled bracket with wings to the joist using one of the supplied screws. Level the bracket. Screw the other side of the bracket/wing assembly to the joist. Two screws on each side makes for a very secure installation. Secure the wire to the bracket using the bracket's wire tie (See Figure 15). The drywall installers will cut the drywall to the exact size of the bracket.

## Concealing Speaker Wire for a Future Installation

Attach the speaker wire in a loop between the ceiling joists and carefully mark the exact location of the wire on a set of plans. Ask the general contractor to inform the drywall installers that the speaker wire loops are concealed for future installation. (See Figure 16).

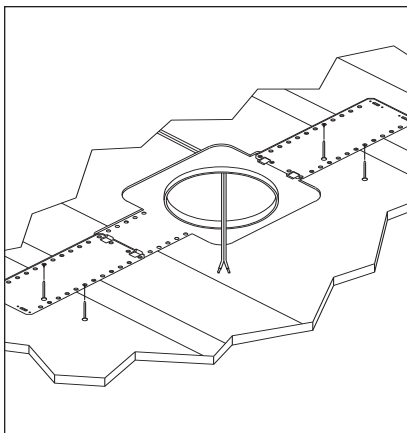

Figure 15

The optional hole saving brackets are installed and the speaker wire is attached to the bracket.

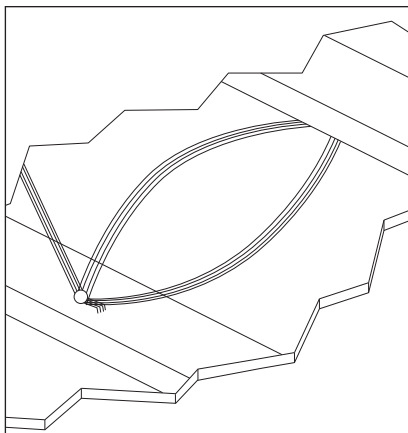

Figure 16

A loop of wire is attached to the joists marking the location of the speaker.

## Installation in Existing Construction

**IMPORTANT:** Before you cut into any wall, review the sections on running wire and speaker placement.

1. When determining the location of the speaker cutout keep in mind that the mounting dogs will extend 3/4" beyond the cutout. Make sure that you do not place the edge of the cutout directly next to a ceiling joist. Locate the joists using a stud sensor or hand-knocking.
2. Once you have determined a possible position for the cutout, drill a 1/8" pilot hole barely through the wallboard or dry wall (1/2" to 5/8" deep in most homes) in the center of your proposed speaker location. BE VERY CAREFUL NOT TO DRILL THROUGH EXISTING WIRES, PIPES, OR STRUCTURE. IF YOU FEEL ANY EXTRA RESISTANCE AS YOU ARE DRILLING, STOP.
3. Cut a foot long piece of coat hanger. Bend the wire (creating a right angle) leaving 5-1/2" at one end (this allows for the extra width of the mounting dogs). Poke the "L-shaped" wire into the pilot hole and turn it in a complete circle and move it into the ceiling cavity to make sure you have approximately 3-3/4" of depth. If the coat hanger movement is obstructed by anything, fill the hole(s) with spackle and try another location. **(See Figure 17).**
4. If the coat hanger moves freely in a complete circle, hold the supplied template up to the ceiling surface. Outline the circular cutout on the ceiling surface with a pencil. Drill a starting point with a 1/4" drill bit.

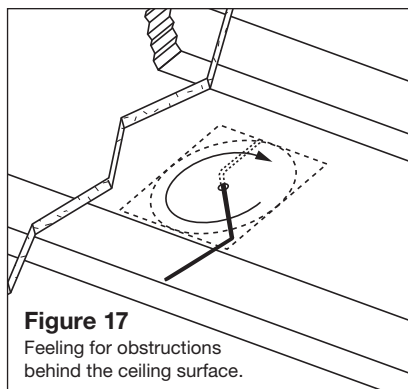

**Figure 17**

Feeling for obstructions behind the ceiling surface.

5. If you are cutting into **drywall** use a sheetrock or keyhole saw. Cut the hole with the saw at a 45° angle. That way, the drywall section can be replaced cleanly if there is an undetected obstruction behind the ceiling surface. BE VERY CAREFUL NOT TO SAW THROUGH EXISTING WIRES, PIPES, OR STRUCTURE. IF YOU FEEL ANY EXTRA RESISTANCE AS YOU ARE CUTTING, STOP.
6. If you are cutting into a **plaster** ceiling, use masking tape to outline your penciled circle and use a razor to score the plaster down to the lath beneath. Then use a chisel to remove all of the plaster within the taped outline. To actually cut the lath, two methods are used professionally; sawing with a metal cutting blade on a sabre saw is the quickest and the **riskiest**. Sawing a lath with a sabre saw can easily vibrate plaster off the ceiling in a completely distant location creating more patch work. If you have the patience, use a pair of tin snips to slowly nip away at the lath instead. There is no risk with this method, it is just time consuming.



## Final Installation in New or Existing Construction

1. If it is possible to lay a batt of insulation into the ceiling cavity, do so. Remember to use equal amounts of insulation for each speaker.
2. Separate the speaker wire so that at least two inches of each conductor are free.
3. Open the no-strip terminal by applying pressure to the red and black levers until an audible “click” is heard.
4. Insert one unstripped wire fully into the black and one into the red terminal. Pay attention to the markings on the wire. Each speaker must be connected to the amplifier in the same way. If unsure, see section “Speaker Phase” located on the following page. Squeeze the red and black levers until they click signifying that they have locked into the wire.
5. Insert the no strip terminal into the corresponding socket on the rear of the speaker. Push it down until it locks in place. The terminal will only fit in the socket in one direction. If the terminal does not properly seat, reverse the terminal
6. Connect the wire which runs to the satellite speakers to the left and right output terminals. Pay attention to the markings on the wire.
7. There are four clamps or mounting “dogs” which hold each speaker in place. The dogs are tightened via four front-baffle screws. To install the speaker, first rotate the dogs inward. Insert the speaker into the cutout and tighten the dogs by turning the screws clockwise. **DO NOT OVER TIGHTEN THESE SCREWS.** Over-tightening the clamps may make the grille difficult to install. (See Figure 18).

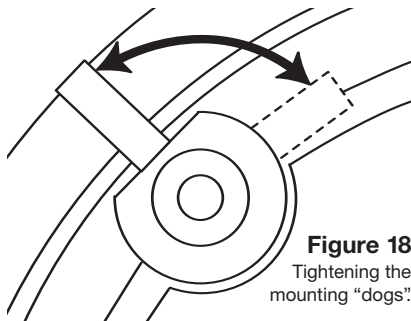

**Figure 18**  
Tightening the mounting “dogs”:

NOTE: The screws will be easier to turn if you “prime” them first. Before installing each speaker, turn the screws in and then turn them back out to their original positions.

### 8. Setting the High Pass Filter

When the “SAT” filter is in the CUT position, all of the bass energy will be produced via the CM8SW. When the switch is in the FULL position, both the satellite speakers and the CM8SW will reproduce the bass signal. Typically, satellites with woofers that are 5-3/8” or smaller will sound best with the filter on. Listen to a loud and well recorded bass passage to evaluate.

### 9. Setting the Subwoofer Low Pass Filter

With the “SUB” switch in the 100Hz position, the CM8SW will only reproduce bass below one hundred cycles. When the switch is in the 140Hz position, the CM8SW will reproduce bass below 140 cycles. Depending on the size of the room, the type of satellite speaker and the subwoofer position, you will prefer one setting to the other. Listen to a loud and well recorded bass passage to evaluate.

10. Install the grille into the speaker. The grilles should fit snugly. If you have difficulty fitting them in, try loosening the mounting dog screws slightly (excessive tightening can distort the shape of the frame holding the grille in place).

## Painting the Speakers

All models may be painted. The plastic will readily accept most paints.

The speakers must be masked prior to painting them. The inside circular portion of the hole template can be used as a paint mask. Remove the outside portion of the template by gently pulling along the perforation. Affix the mask to the front of the speaker by friction-fitting the mask into the bezel.

The grilles should be painted before they are installed. For all models, the best results will be obtained by using a spray gun or airless sprayer, thinning the paint (prevents clogging of grille holes), and by applying several light coats instead of one heavy one.

## Speaker/Subwoofer Phase

Speaker wire has two conductors. One conductor is attached to the negative (–) terminals and one conductor is attached to the positive (+) terminals of both your speaker and your amplifier. Usually, the wire is marked for your convenience. There are different ways wires are marked: a stripe on one wire, a ribbed area of one conductor you can only feel, different colors of metal wire on each conductor, or there might be a fabric strand or string wound into one of the conductors. Of course, there are some wires which appear completely identical. Be careful, or you might make a mistake.

If you make a mistake, there are three possibilities:

### 1. *Subwoofer Input Phase Reversal*

The Left Input of the Subwoofer is out of Phase with the Right Input. If this is the case, you will hear almost no output out of the subwoofer when playing a loud bass passage. Try reversing one of the subwoofer inputs. If the sound gets a

great deal louder, that was the problem. If bass sound was reduced return the connections to their original state.

### 2. *Subwoofer /Satellite Relative Phasing*

An acoustically out-of-phase sat/sub combination works against each other and the sound of the overall system will be lacking in bass. This might be because of the *position of the subwoofer* rather than an error in wiring. Try reversing the phase of both the left and the right outputs of the subwoofer. Make sure you evaluate (listen) from the primary listening position.

### 3. *Satellite Left-Right Phase Reversal*

If the right satellite is reversed in phase from the connections on the left satellite, you will hear reduced bass and a “phasey” diffused vocal image. If you suspect the sound is not right and you cannot see any markings on the wire, try this simple test:

- a. Stand half way between the two satellite speakers.
- b. Play some vocal music with the amplifier or radio set to Mono.
- c. Listen to the apparent placement of the vocals.
- d. Turn off the amplifier and reverse one of the connections on the subwoofer.
- e. Repeat the listening test with the same setting of the volume control. When the sound has a richer bass, is slightly louder and the vocal image is “focused” the satellites are working together or “in-phase”.

# Operation

## Congratulations

A concealed CM8SW subwoofer installation frees you to use your tone controls, play the system loudly and enjoy deep extended bass, even if your satellite speakers are small. When used with satellite speakers that have substantial bass of their own, the CM8SW tightens the deep tones and augments the bass musically.

## Listening at Higher Volumes

It requires more power to achieve a reasonable volume of sound in a large room than it does in a small room. It is possible (even if you are not a teenager) to turn the volume so high that the amplifier *runs out of power*. This creates “clipping” distortion. If you are using an extremely powerful amplifier it may be possible to hear clicking or buzzing sounds from the subwoofer as it tries to reproduce too loud a sound. If you hear these sounds turn the volume down.

More typically you will hear clipping distortion through your satellite speakers. Clipping distortion makes treble sound very harsh and unmusical. When you hear harsh sounding treble from any good speaker, turn the volume down immediately! Those harsh sounds are masking some much more powerful ultra-high-frequency sound spikes which will quickly damage any fine loudspeaker. You are much less likely to damage a speaker with a large amplifier because it will be very loud indeed before it produces any clipping distortion.

## Cleaning

You can clean the speaker with a dampened soft cloth or paper towel. If the speaker is mounted high up on the ceiling, use a broom to gently brush it off.

# Specifications

## CM8SW

### Driver Complement

8" dual voice-coil injection molded TCC (Talc, carbon and ceramic-filled) woofer with butyl rubber surround

### Design Principle

Infinite baffle for large and varying air volumes

### Recommended Amplifier Power

10 to 150 watts per channel

### Impedance

8 ohm

### Frequency Response

35 – 140Hz, +/- 3dB

### Sensitivity

90 dB for 2.83 volts of pink noise, measured at 1 meter on axis

### Overall Exterior Frame Dimensions

10-5/8" diameter

### Depth Behind Wall

4" (based on 1/2" drywall)

### Wall Cut-Out Dimensions

9-1/2" diameter

### Connections

Dual patented two-piece, no-strip speaker wire terminal, accommodates 12-18 gauge

# WARRANTY REGISTRATION CARD

Model Purchased \_\_\_\_\_

Serial Number \_\_\_\_\_

Date Purchased (month/day/year) \_\_\_\_\_

Dealer Name and Location \_\_\_\_\_

Dr.     Miss     Mr.     Mrs.     Ms.

Name \_\_\_\_\_

Address \_\_\_\_\_

City \_\_\_\_\_ State \_\_\_\_\_ Zip \_\_\_\_\_

Telephone ( \_\_\_\_\_ ) \_\_\_\_\_

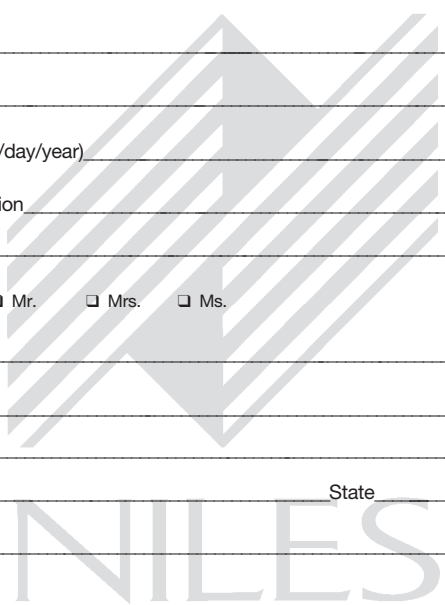

**Please take a moment to fill out our warranty registration card. The information helps us to get to know you better and develop the products you want**

## Age:

- Under 25
- 25-34
- 35-44
- 45-54
- 55 & over

## Income:

- Under \$24,999
- \$25,000-\$34,999
- \$35,000-\$44,999
- \$45,000-\$59,999
- \$60,000-\$74,999
- \$75,000-\$99,999
- Over \$99,999

## Occupation:

- Arts/Entertainment
- Business Owner
- Engineer
- Finance/Accounting
- General Office
- Management
- Professional
- Sales/Marketing
- Student
- Tradesperson

## Musical tastes:

(Please check all that apply)

- Alternative
- Classical
- Country
- Jazz
- New Age
- Popular
- R&B
- Rock
- Other \_\_\_\_\_

## How did you hear about Niles?

- Architect/Developer
- Custom Installer
- Direct Mail
- Friend/Family
- In-Store Display
- Interior Designer
- Magazine Ad
- Mail-Order Catalog
- Newspaper Ad
- Product Brochure
- Product Review
- Retail Salesperson

## What magazines do you read?

1. \_\_\_\_\_
2. \_\_\_\_\_
3. \_\_\_\_\_

## Who will install the product?

- Custom Installer
- Electrician
- Friend
- Myself

## Which factor(s) influenced the purchase of your Niles product?

(Please check all that apply)

- Ease of Use
- Price/Value
- Product Features
- Quality/Durability
- Reputation
- Style/Appearance
- Warranty

## Do you . . . ?

Own a House. If yes, how many square feet? \_\_\_\_\_

- Own a Town House/Condominium/Co-op
- Rent an Apartment
- Rent a House

## Are you interested in receiving literature on other Niles products?

- Yes     No

## Are there products/capabilities that you would like to see introduced?

\_\_\_\_\_  
\_\_\_\_\_  
\_\_\_\_\_  
\_\_\_\_\_

PLEASE FILL OUT THE  
WARRANTY REGISTRATION  
CARD ON THE REVERSE SIDE,  
DETACH, AND MAIL TO:

**Niles Audio Corporation**  
**Warranty Registration Dept.**  
**P.O. Box 160818**  
**Miami, Florida 33116-0818**

DETACH HERE



# Limited Warranty

Niles Audio Corporation ("NILES") warrants its loudspeaker products to the original purchaser to be free of manufacturing defects in material and workmanship for a period of five years from date of purchase.

This Warranty is subject to the following additional conditions and limitations. The Warranty is void and inapplicable if NILES deems that the product has been used or handled other than in accordance with the instructions provided by the manufacturer, including but not limited to damage caused by accident, mishandling, improper installation, abuse, negligence, or normal wear and tear, or any defect caused by repair to the product by anyone other than NILES or an authorized NILES dealer.

To obtain warranty service, take the unit to the nearest authorized NILES dealer, who will test the product and if necessary, forward it to NILES for service. If there are no authorized NILES dealers in your area, you must write to NILES and include your name, address, model and serial number of your unit, along with a brief description of the problem. A factory Return Authorization Number will be sent to you. **DO NOT RETURN ANY UNIT WITHOUT FIRST RECEIVING WRITTEN AUTHORIZATION AND SHIPPING INSTRUCTIONS FROM NILES.**

If the above conditions are met, the purchaser's sole remedy shall be to return the product to NILES, in which case NILES will repair or replace, at its sole option, the defective product without charge for parts or labor. NILES will return a unit repaired or replaced under warranty by shipping same by its usual shipping method from the factory (only) at its expense within the United States of America. **THERE ARE NO OTHER WARRANTIES, INCLUDING WITHOUT LIMITATION, EITHER EXPRESS OR IMPLIED WARRANTIES OF MERCHANTABILITY OR FITNESS FOR A PARTICULAR PURPOSE, WITH RESPECT TO THE PRODUCT.**

**REPAIR OR REPLACEMENT AS PROVIDED UNDER THIS WARRANTY IS THE EXCLUSIVE REMEDY OF THE CONSUMER/PURCHASER. NILES SHALL NOT BE RESPONSIBLE FOR ANY INCIDENTAL OR CONSEQUENTIAL DAMAGES EXCEPT TO THE EXTENT PROVIDED (OR PROHIBITED) BY APPLICABLE LAW.**

Some states do not allow the exclusion or limitation of incidental or consequential damages, so the above limitation may not apply to you. This warranty gives you specific legal rights, and you may also have other rights which vary from state to state.

For the name of your nearest authorized NILES dealer contact:

**NILES AUDIO CORPORATION**  
P.O. BOX 160818, Miami, Florida 33116-0818.

Please fill in your product information and retain for your records.

Model CM8SW

Serial No. \_\_\_\_\_

Purchase Date \_\_\_\_\_



[www.nilesaudio.com](http://www.nilesaudio.com)

**Niles Audio  
Corporation**

12331 S.W. 130 Street  
Miami, Florida 33186

Tel: (305) 238-4373

Fax: (305) 238-0185

Printed in China

© 2004 Niles Audio Corporation. All Rights Reserved. Niles, the Niles logo, and Blending High Fidelity and Architecture are registered trademarks of Niles Audio Corporation. MicroPerf is a trademark of Niles Audio Corporation. All other trademarks are the property of their respective owners. Because we constantly strive to improve our products, Niles reserves the right to change product specifications without notice. The technical and other information contained herein is not intended to set forth all technical and other specifications of Niles products. Additional information can be obtained on-line. Printed in China. DS00292ACN